

VNG 903

Setting tool for blind rivet nuts and studs
Pneumatic-hydraulic | stroke-controlled

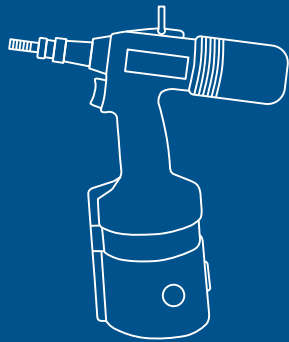

MOVIE



The stroke-controlled solution for large tasks – optionally up to M12.

The sophisticated design and individual setting options make the **HONSEL** VNG 903 your perfect tool for the easy and reliable setting of all common blind rivet nuts. These are **automatically threaded** onto the threaded mandrel through light pressure. Threading is likewise stopped automatically; the threading time can be set.

Convenient, simple, practical.

STROKE CONTROLLED



Exact adjustment of the setting stroke via scale on the adjustment cap.



Easy setting of even thick-walled blind rivet nuts – optionally up to M12!

Family facts on the **HONSEL** pneumatic tools on page 65.

VNG 903

| | M3 | M4 | M5 | M6 | M8 | M10 | M12 |
|---------------------------------|-----------------|---|----|----|----|-----|---|
| Material | Aluminium | | | | | | optional |
| | Steel | | | | | | optional |
| | Stainless steel | | | | | | optional |
| Material | Steel | | | | | | |
| Weight | 2.7 kg | ZUG 29,000 N at 7 bar | | | | | Screwing in 1800 rpm Unscrewing 2500 rpm |
| Pressure | 5-7 bar | < 75 dB(A) (68.32) | | | | | G 1/4 inside thread, can be fitted on left or right |
| Air consumption | 7.5 litres | • 1x VNG 903 pneumatic-hydraulic riveter in HONSEL L-Boxx® | | | | | |
| Hub | 9 mm | • 5x conversion kits for blind rivet nuts • 1 bottle of hydraulic oil with refill unit | | | | | |
| Item no. 320.903.000.000 | | | | | | | |



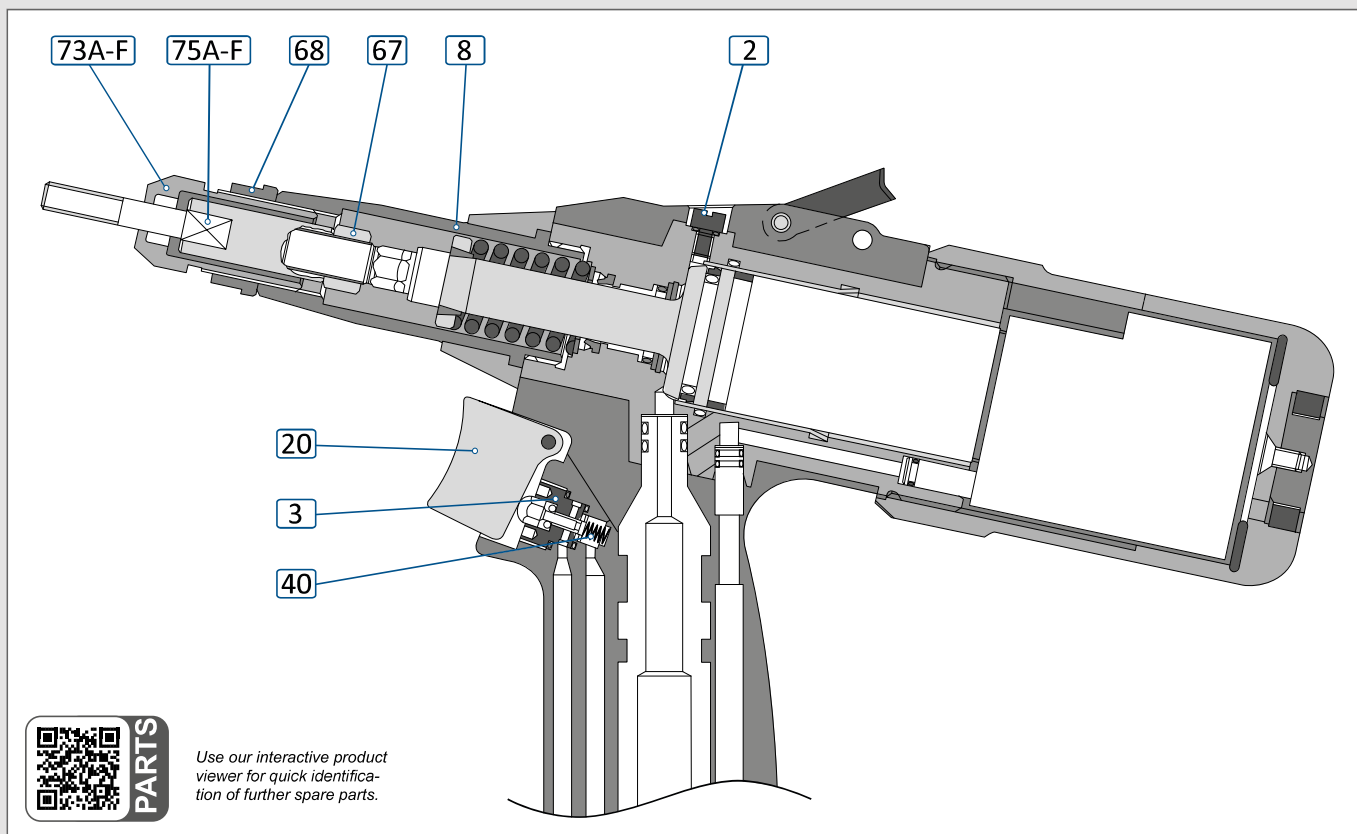

Spare and wear parts

| | | |
|----|--------------|---------------------------------|
| 2 | 321101000027 | Oil drain plug including o-ring |
| 3 | 321102000007 | Release valve |
| 20 | 321102000016 | Trigger |
| 8 | 321903000016 | Front sleeve |
| 40 | 321102000036 | Pressure spring trigger |
| 67 | 361802191075 | Lock nut M9x0.75 |
| 68 | 321801000074 | Lock nut M18x1 |

Nosepieces

| | | |
|-----|--------------|---------------|
| 73A | 311800000204 | Nosepiece M4 |
| 73B | 311800000205 | Nosepiece M5 |
| 73C | 311800000206 | Nosepiece M6 |
| 73D | 311800000208 | Nosepiece M8 |
| 73E | 311800000210 | Nosepiece M10 |
| 73F | 311800000212 | Nosepiece M12 |

Mandrels/sleeves

| | | |
|-------|--------------|----------------------------|
| 75A | 321800008040 | Mandrel M4 |
| 75B | 321800008050 | Mandrel M5 |
| 75C | 321800008060 | Mandrel M6 |
| 75D | 321800008080 | Mandrel M8 |
| 75E | 321800008100 | Mandrel M10 |
| (75F) | 321800008120 | Mandrel M12 |
| 74A | 321800009040 | Threaded sleeve Ribbolt M4 |
| 74B | 321800009050 | Threaded sleeve Ribbolt M5 |
| 74C | 321800009060 | Threaded sleeve Ribbolt M6 |
| 74D | 321800009080 | Threaded sleeve Ribbolt M8 |



The **stroke circlip** prevents an unwanted shifting of the adjusting cap.

for VNG 701/801/802/903:
321801000080



- ⚠ Special accessories, nosepieces and mandrels, for example, extended, or for UNC/ UNF coarse threads or for inside riveting locations are available on request.
- ▶ Pneumatic accessories on page 81.



HONSEL VNG 903 in day-to-day use.
Guaranteed installation – powerful and reliable